

# Face Seal Fittings

## TFO Series L-ring Face Seal Fittings

### Features

- ⦿ Reduced internal entrapment
- ⦿ Lubricant-free L-ring seal
- ⦿ Controlled L-ring extrusion to prevent over-tightening
- ⦿ Butt weld connection to ensure the system unhindered
- ⦿ Standard surface roughness finished to an average of Ra 20 µin. (0.51 µm)
- ⦿ Each fitting marked with size, material and heat number



### Technical Data

- ⦿ Sizes range from 1/4" to 1"
- ⦿ Materials:

Material	Bar Stock	Designator
316 SS	ASTM A276, ASME SA479	SS
316L SS		6L

- ⦿ Working Pressure @ 100°F (37°C):

Tube OD.	Working Pressure psig (bar)
1/4 in.	2500 (172)
1/2 in.	2000 (137)
3/4 in.	1500 (103)
1 in.	
12 mm	2000 (137)

- ⦿ Working Temperature:  
Temperature ranges for TFO fittings are restricted by the L-ring materials.

Material	Designator	Working Temperature
PTFE	T	- 50°F to 450°F (- 45°C to 232°C)

## Testing

Every TFO fitting is Helium leak tested to a maximum allowable leak rate of  $4 \times 10^{-9}$  std cm<sup>3</sup>/s.

## Ordering Information

- ⦿ Each component can be ordered separately.
  - ⦿ Add the material designator as a prefix, cleaning and packaging code as a suffix to the basic ordering number to get the complete ordering number.
  - ⦿ Cleaning and Packaging
    - a. FC-01 Standard Cleaning and Packaging for general industrial procedures. No suffix is needed.
    - b. FC-02 Special Cleaning and Packaging, to ensure compliance with product cleanliness requirement as stated in ASTM G93 Level C. Add "-F2" as a suffix when needed.
- Example: For 316L SS standard 1/4" gland with FC-02 Special Cleaning and Packaging, the ordering number is 6L-G-TFO4-TB4-F2.

## Installation Instructions

1. Assemble the gland, nut and gasket as below. Finger tight the nut.

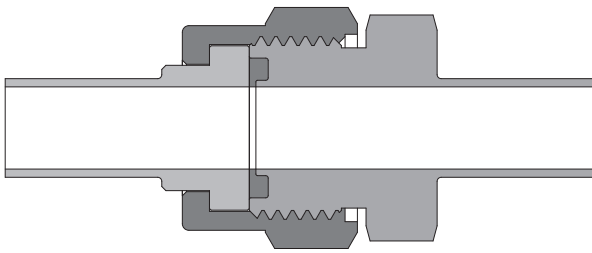

2. Tighten the nut 1/8 turn with a wrench while holding the fitting body steady.

## Cautions

- ⦿ Dimensions are for reference only and are subject to change.
- ⦿ Inspect the O-ring each time the groove housing is dismantled.
- ⦿ Before welding the body, the L-ring should be removed to prevent possible damages.
- ⦿ Tungsten Inert Gas Welding (TIG) is recommended.
- ⦿ Do not loosen or tighten fittings when system is pressurized.

## Glands

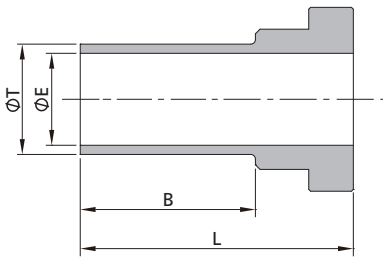

T-Tube O.D. (in.)	Wall Thickness (in.)	Basic Ordering Number	Dimensions, in. (mm)		
			L	B	E
1/4	0.035	-G-TFO4-TB4	0.67 (17.0)	0.25 (6.4)	0.18 (4.6)
1/4	0.035	-G-TFO4-TB4-12	1.17 (29.7)	0.75 (19.1)	0.18 (4.6)
1/2	0.049	-G-TFO8-TB8	1.17 (29.7)	0.75 (19.1)	0.40 (10.2)
1/2	0.065	-G-TFO8-TB8×0.065	1.17 (29.7)	0.75 (19.1)	0.37 (9.4)
3/4	0.065	-G-TFO12-TB12	1.24 (31.5)	0.75 (19.1)	0.62 (15.7)
1	0.065	-G-TFO16-TB16	1.45 (36.8)	0.96 (24.4)	0.87 (22.1)

T-Tube O.D. (mm)	Wall Thickness (mm)	Basic Ordering Number	Dimensions, in. (mm)		
			L	B	E
12	1	-G-TFO8-MTB12	1.17 (29.7)	0.75 (19.1)	0.39 (10.0)

## Nuts

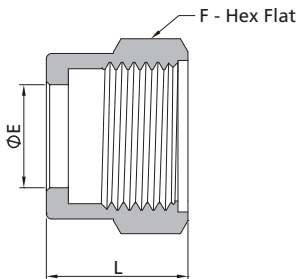

Basic Ordering Number	Dimensions, in. (mm)		
	L	E	F
-N-TFO4	0.75 (19.1)	0.39 (9.9)	11/16 (17.5)
-N-TFO8	0.84 (21.3)	0.61 (15.5)	1 (25.4)
-N-TFO12	0.90 (22.9)	0.94 (23.9)	1 1/2 (38.1)
-N-TFO16	0.90 (22.9)	1.25 (31.8)	1 3/4 (44.5)

## Tube Butt Weld Bodies

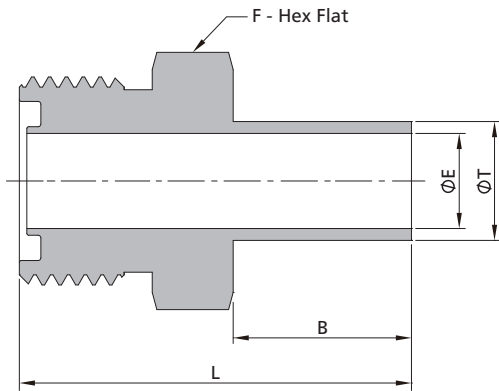

T-Tube OD. (in.)	Wall Thickness (in.)	Basic Ordering Number	Dimensions, in. (mm)			
			L	B	E	F
1/4	0.035	-CW-TFO4-TB4	1.03 (26.2)	0.25 (6.4)	0.18 (4.6)	5/8 (15.9)
1/4	0.035	-CW-TFO4-TB4-12	1.53 (38.9)	0.75 (19.1)	0.18 (4.6)	5/8 (15.9)
1/2	0.049	-CW-TFO8-TB8	1.65 (41.9)	0.75 (19.1)	0.40 (10.2)	15/16 (23.8)
1/2	0.065	-CW-TFO8-TB8x0.065	1.65 (41.9)	0.75 (19.1)	0.37 (9.4)	15/16 (23.8)
3/4	0.065	-CW-TFO12-TB12	1.75 (44.4)	0.75 (19.1)	0.62 (15.7)	1 5/16 (33.3)
1	0.065	-CW-TFO16-TB16	1.99 (50.5)	0.96 (24.4)	0.87 (22.1)	15/8 (47.6)

T-Tube OD. (mm)	Wall Thickness (mm)	Basic Ordering Number	Dimensions, in. (mm)			
			L	B	E	F
12	1	-CW-TFO8-MTB12	1.65 (41.9)	0.75 (19.1)	0.39 (10.0)	15/16 (23.8)

## L-ring Seal

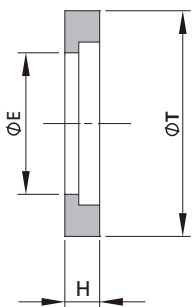

Basic Ordering Number	Dimensions, in. (mm)		
	T	E	H
-GT-TFO4	0.38 (9.6)	0.18 (4.6)	0.07 (1.8)
-GT-TFO8	0.64 (16.2)	0.40 (10.2)	0.10 (2.5)
-GT-TFO12	0.92 (23.4)	0.62 (15.7)	0.10 (2.5)
-GT-TFO16	1.30 (33.0)	0.87 (22.1)	0.14 (3.6)

Add the L-ring material designator in page F-38 as a prefix to the basic ordering number to get the complete ordering number.

Example: T-GT-TFO4